

Overlay on side, top and bottom panel of the cabinet.

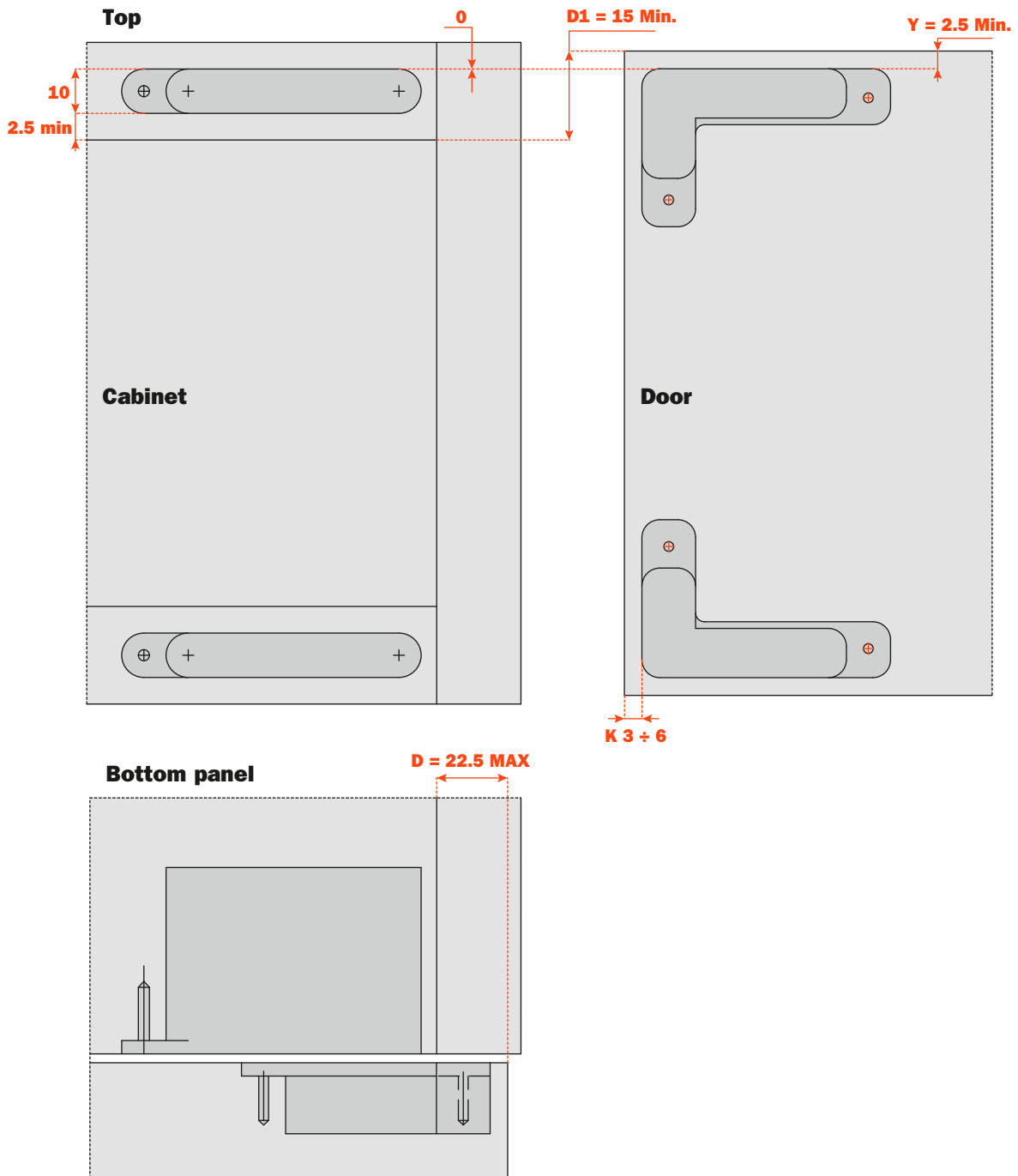

Workings on the top and the bottom panel for the application of the hinge.

Workings on the door for the application of the hinge.

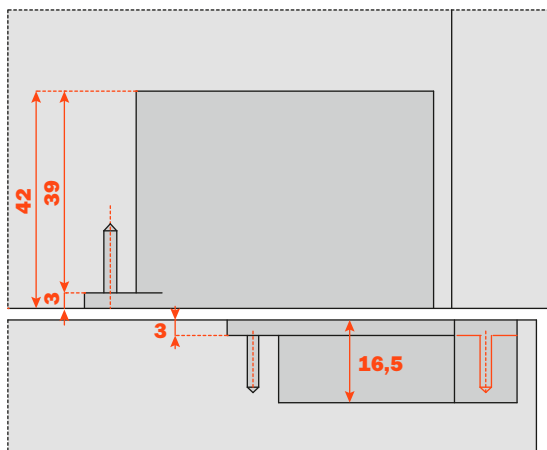
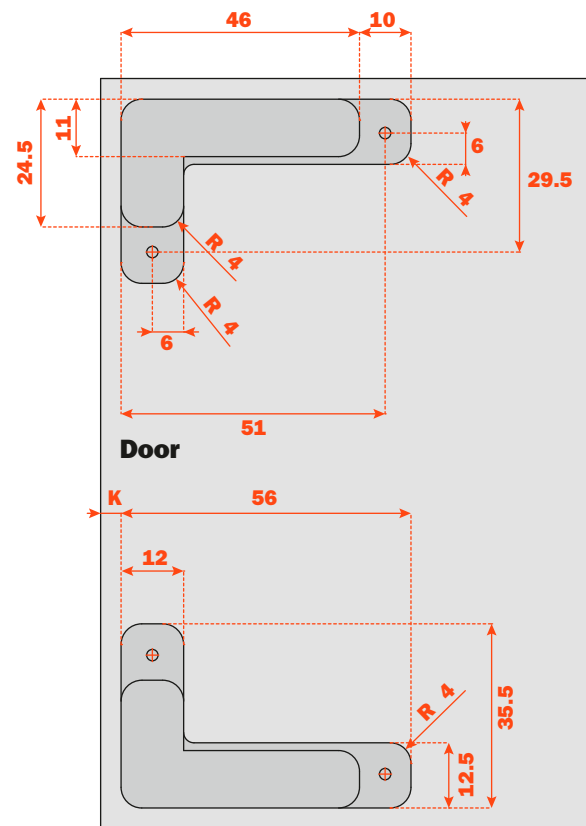
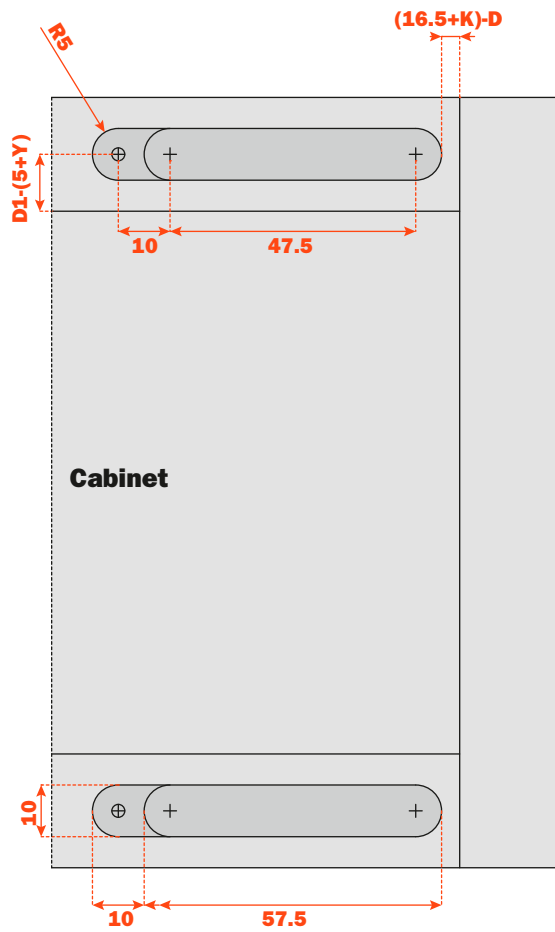

Workings on the frame DEL6LP300_ and use of the corner connectors DEL6BSFV02.

Overlay on side, top and bottom panel of the cabinet.

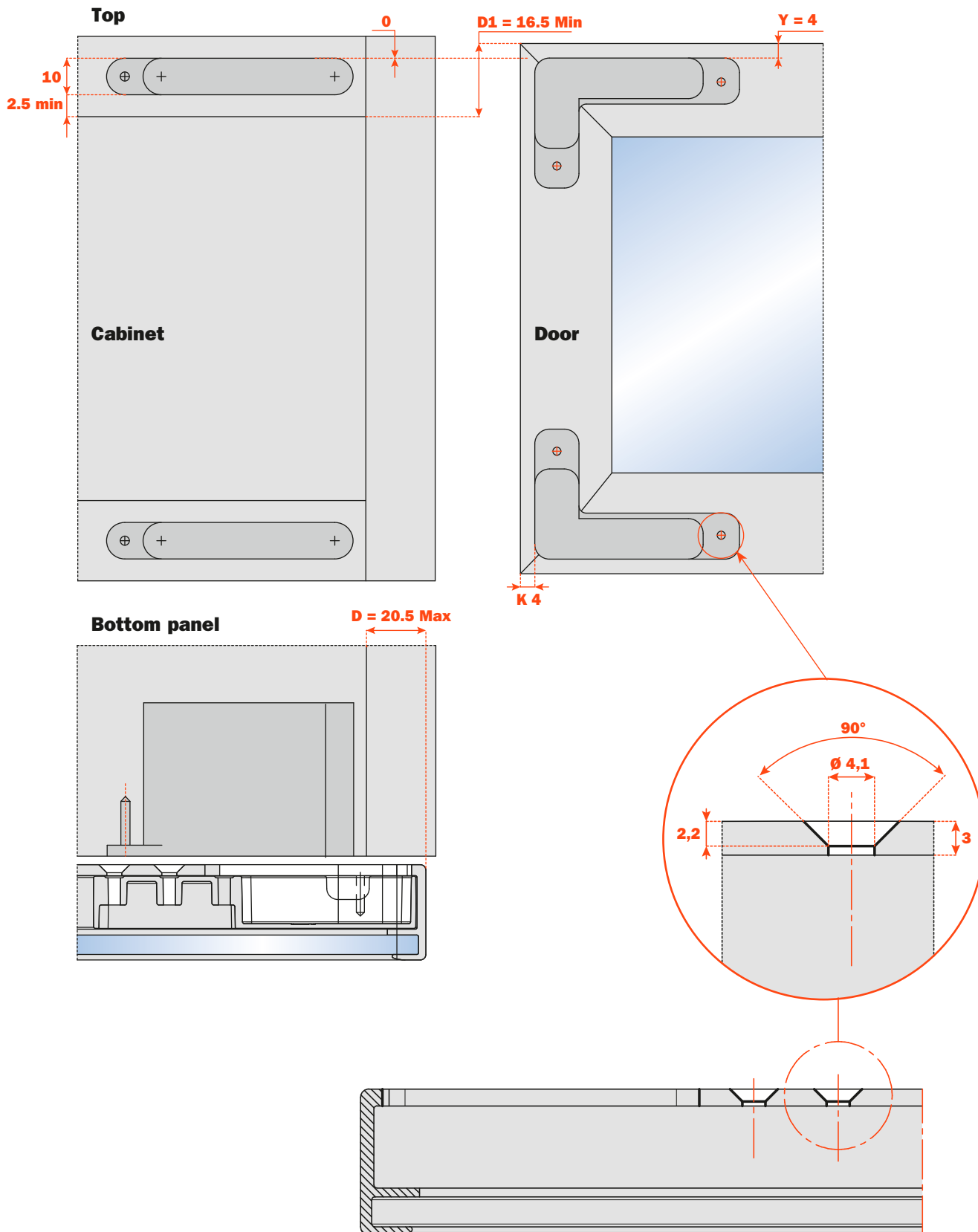

Workings on the top and the bottom panel for the application of the hinge.

Milling scheme for aluminium-framed doors DEL6LP300_

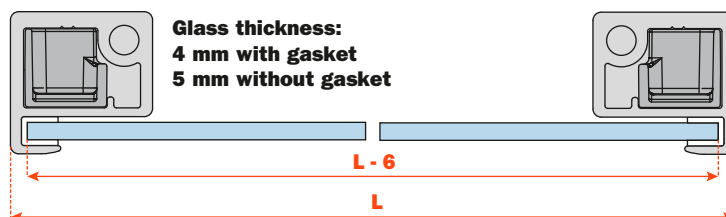
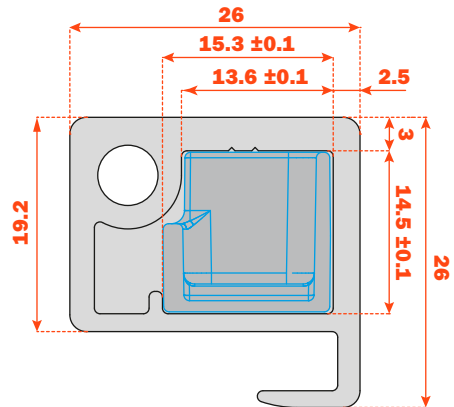
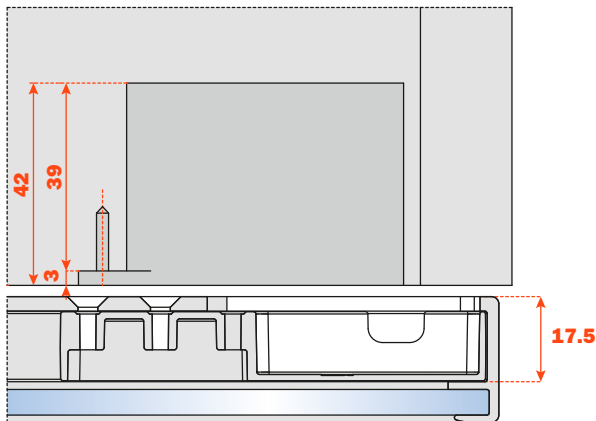
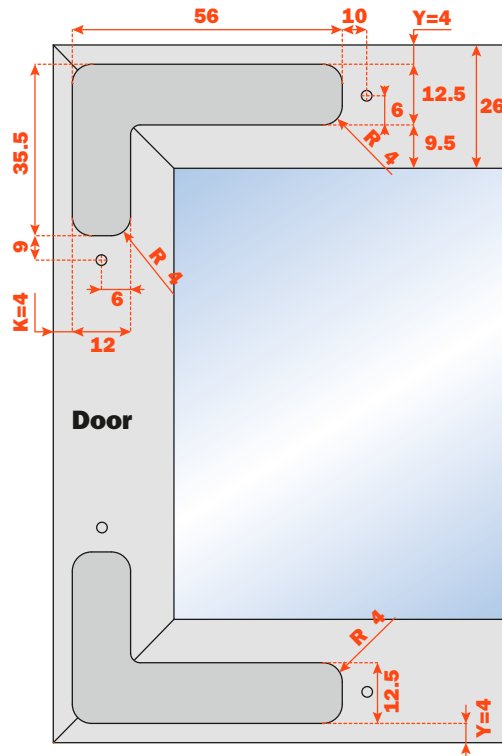
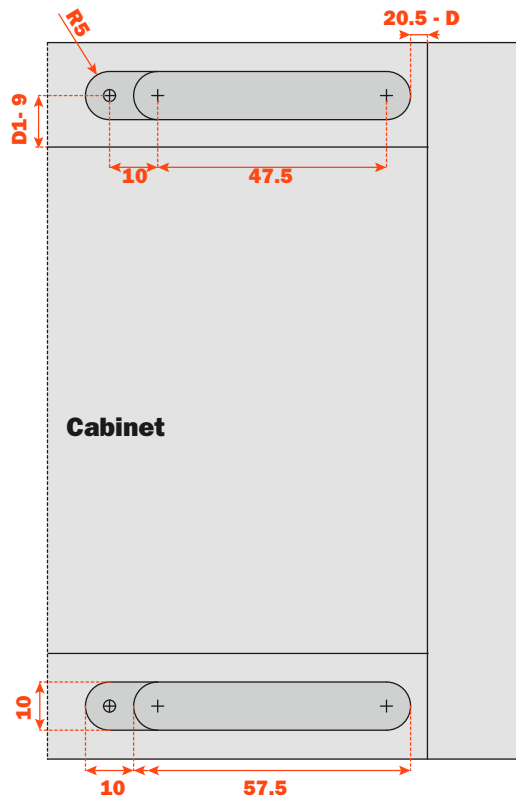

Workings on the frame DEL9LP300_ and use of the corner connectors DEL6BSFV02.

Overlay on side, top and bottom panel of the cabinet.

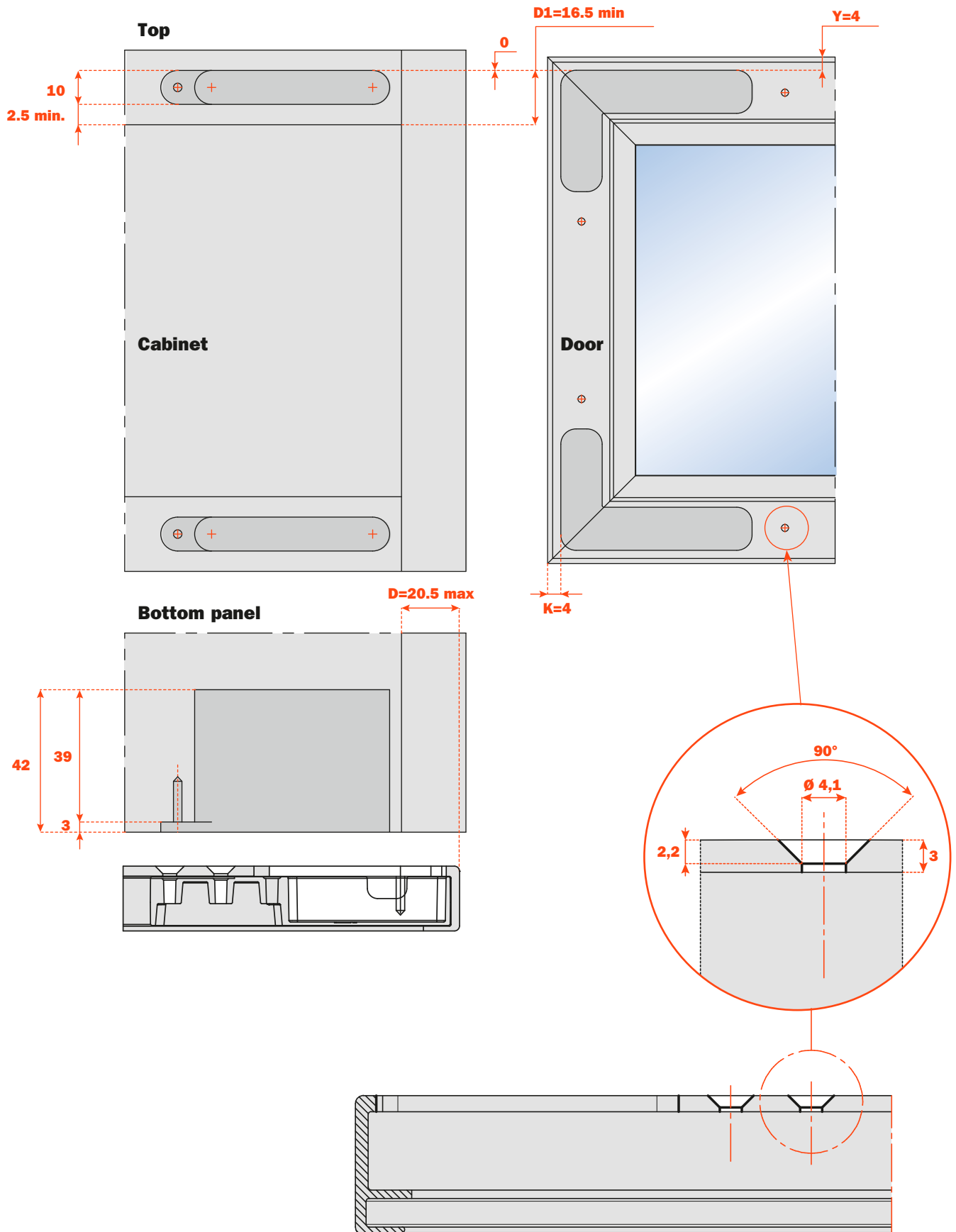

Workings on the top and the bottom panel for the application of the hinge.

Milling scheme for aluminium-framed doors DEL9LP300_

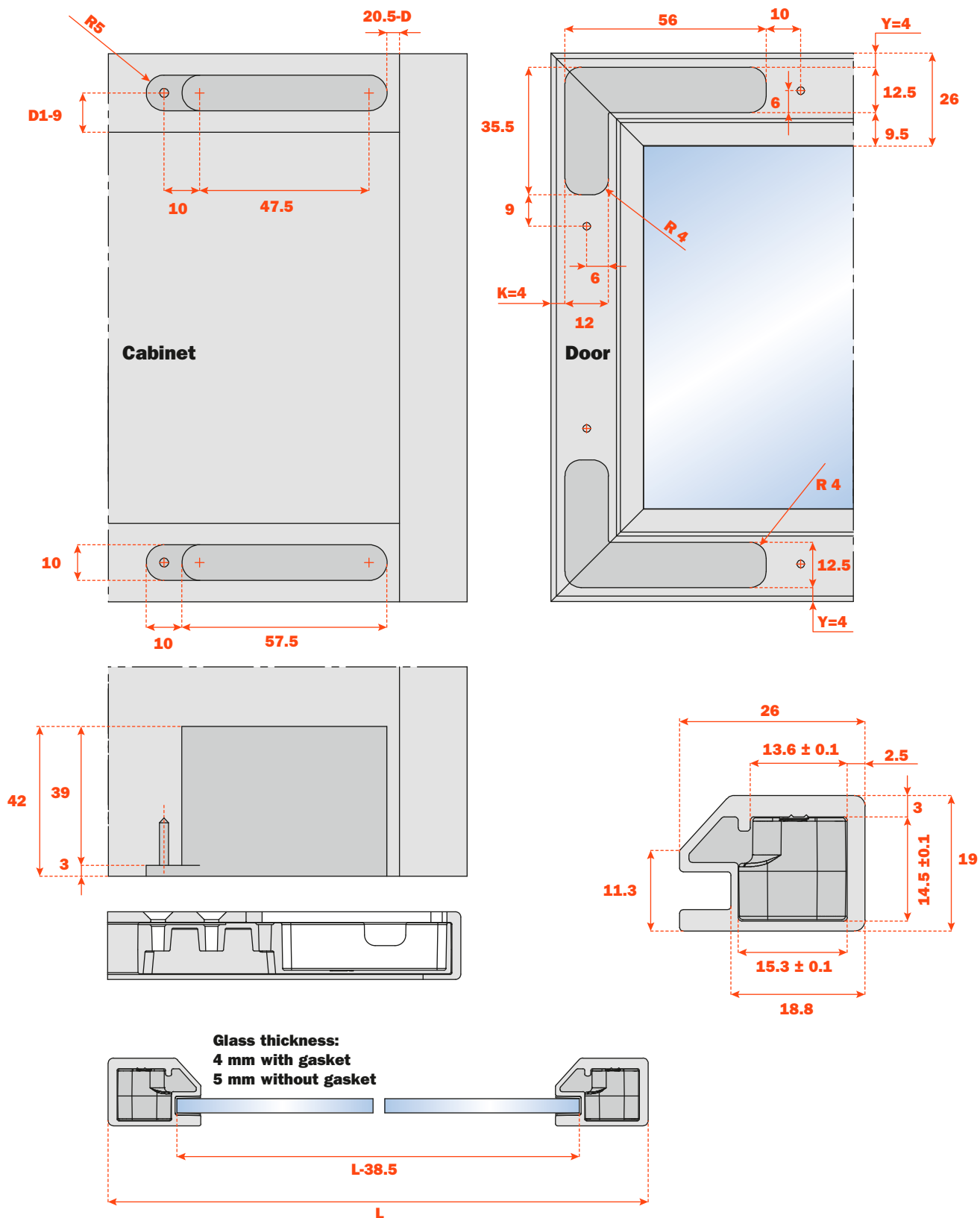

Sideways adjustment from +2 to -2

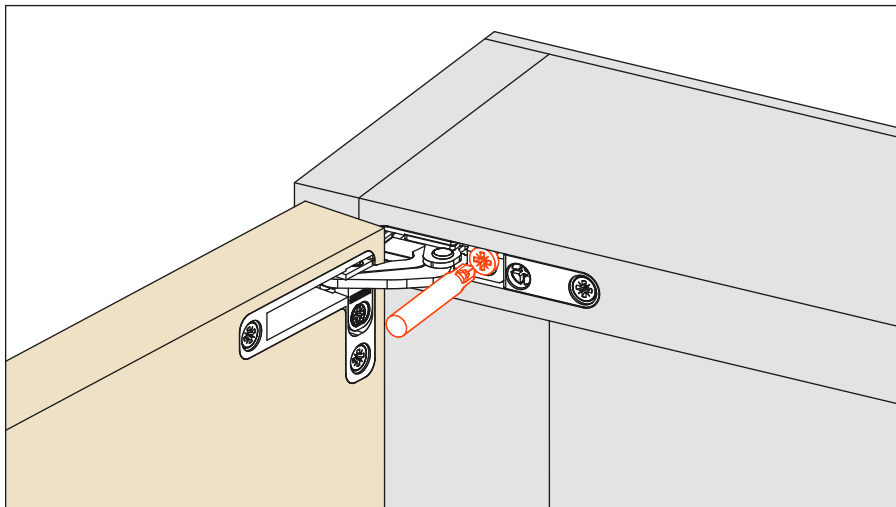
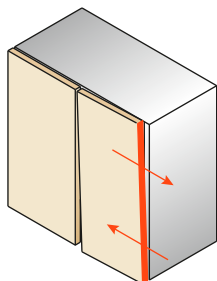

Depth adjustment from +2 to -0.5

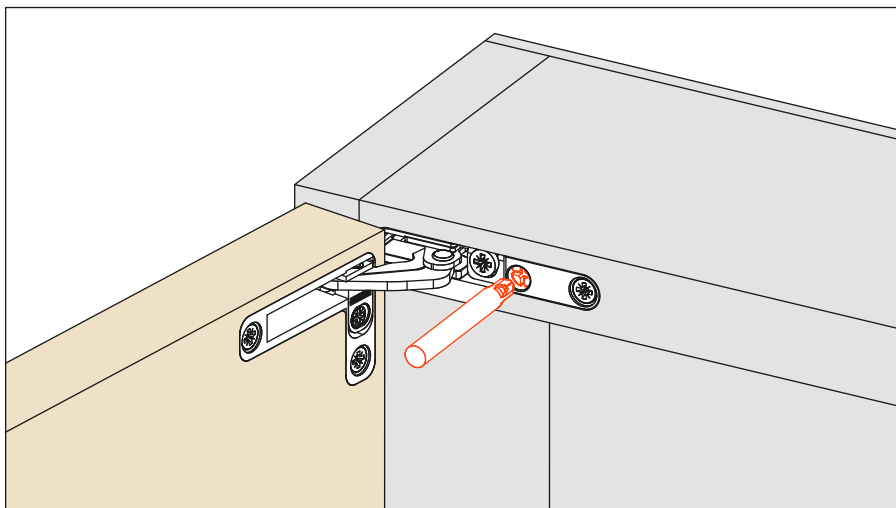
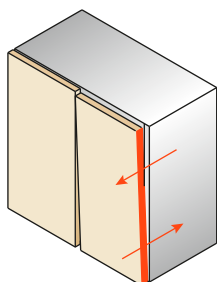

Height adjustment from +1.5 to -1.5

